

Monochrome laser product



Lexmark M1145 and M3150

Impressive performance



Mono



Duplex
printing



Up to 50 ppm



Security



2.4" LCD and 4.3"
color touch screen



Network



Eco-Mode



Founded in 1991 from an IBM heritage in Lexington, Kentucky, Lexmark is focused on delivering tailored solutions to solve the unique challenges businesses face. Lexmark's broad portfolio of high-quality products, solutions and services help improve productivity, increase efficiency and empower employees to perform at their best.

Eco-responsible

Printing responsibly and reducing the impact of printing on the environment is a win for your business and your budget. Our goal is to design, package and deliver innovative products and solutions that produce high-quality output with reliable performance. And at the same time, help you minimize the number of cartridges you use over the life of a printer and conserve paper and energy.

The Lexmark Cartridge Collection Program provides a variety of methods for free returns of your empty cartridges to Lexmark or our collection partners. Program availability and details vary by country.

Environmental protection is a shared responsibility

Through work with industry groups, Lexmark helps guide the formation of standards and guiding principles for environmental sustainability.

Our memberships include:

- ▶ AeA Europe
- ▶ Ecma International
- ▶ Electronics Industry Citizenship Coalition (EICC)
- ▶ DIGITALEUROPE
- ▶ European Information & Communications Technology
- ▶ Industry Association (EICTA)
- ▶ Information Technology Industry Council (ITI)
- ▶ ITI Environmental Leadership Council





Compact power

The Lexmark M1145 and M3150 systems bring power and speed together in a space-saving size. Built to handle the requirements of a busy work environment, the M1145 and M3150 will produce high-quality professional output in next to no time.

- ▶ Process even the most complex jobs utilizing the 800MHz dual-core processing power and up to 3GB of memory
- ▶ Get work done quickly with print and copy speeds up to 50 ppm and produce your first page in as little as 6.5 seconds
- ▶ Produce professional output with a system that delivers consistent image quality on a diverse range of materials
- ▶ Instant warm-up fuser helps reduce energy consumption and improve time to first page

Business productivity

The Lexmark M1145 and M3150 combine exceptional performance with time-saving applications designed to drive greater efficiency and simplify your work processes.

- ▶ With these systems, you can print from desktops as well as mobile devices that can run applications
- ▶ A maximum input capacity of up to 2,300 sheets and our state-of-the-art paper handling keeps jobs moving with reliable performance

Easy and intuitive

The Lexmark M1145 and M3150 are designed for easy operation to allow you to stay focused on customer engagements instead of routine maintenance.

- ▶ The easy to read 2.4-inch color display or the intuitive 4.3-inch color touch screen with audible feedback make completing tasks simple
- ▶ Print preview on the M3150 helps you select documents or specific pages within a document to print only what you need
- ▶ Extend your environmental responsibility with energy-efficient settings such as the hibernate mode which reduces the energy usage to less than one watt
- ▶ Manage your devices with available software

Propel your business forward

Our solutions are designed with your productivity in mind. The Lexmark M3150 platform lets you interact with business applications directly on the device or with a server, on premise or hosted in the cloud. Reduce unnecessary printing and simplify work processes with Lexmark solutions.

Navigate to efficiency

The Lexmark color touch screen is a key access point to your device. The customizable, 4.3-inch interface gives you the ability to preview thumbnails of documents prior to printing, as well as change print job settings at the device. You can even view, select and print specific pages within a document directly from the touch screen. Its easy-to-use, intuitive navigation provides fast access to the functions and shortcuts.

Examples of preloaded solutions on M3150 printer:



Forms and Favorites

Eliminate waste and inefficiencies associated with preprinted forms. Store frequently printed forms, marketing materials or other documents online, then print them on demand.



Eco Settings

Lets you change up to six different device settings to enhance environmental savings: Eco-mode, two-sided printing, time to standby mode, time to power saver mode, screen brightness and quiet mode.



Customer Support

This application provides you with an easy way to send information about your device to your authorized dealer or internal help desk.



Address Book

Allows users to manage the device's internally stored data, contacts and scan destination (if supported applications are installed) from the device's e-Task touch screen interface, as well as from the embedded web server.

Professional-quality output is only part of the story

By leveraging our industry expertise, you can generate efficiency and increase productivity across business processes to gain the power you need to move ahead. Lexmark technology solutions are tailored to your business environment—where business interactions and decisions are happening.

Empower your employees with workflow solutions that refine work processes, capture critical data and deliver information to the right place, at the right time and in the right format.

Contact your Lexmark Business Solutions Dealer for specific vertical solutions.*

Keep sensitive information and documents secure

Lexmark builds network devices with security in mind to protect your data and documents throughout your entire workflow. Our wide range of security functions include device management, device hardening and device operation.

Device management. Tools include administrative access and passwords, HTTPS, SNMPv3, IP security (IPSec) and 802.1x support to remotely monitor and manage device usage.

Device hardening. Includes port filtering, TCP connection filtering, hard disk encryption, hard disk wiping and digitally signed firmware updates that enhance the security of the device's network interface.

Device operation. Reduce vulnerabilities with authentication and authorization features, address book lookup via LDAP over SSL and device lockout for protection of user information.

Lexmark has shown its strength and leadership with respect to security

- ▶ Forming and chairing the group that created the IEEE 2600 standards for security on hardcopy devices
- ▶ Becoming the first hard-copy device manufacturer to take a holistic approach with the National Information Assurance Partnership (NIAP) Common Criteria evaluation

*Optional software available. Licensing fees apply.



M1145 with 2.4-inch LCD screen



M3150 with 4.3-inch color touch screen



Intuitive color display or touch screen

Operate your device with ease through smart and intuitive navigation. Receive audible feedback when you use the touch screen.



Flexible media handling

Print on a range of media with built in 2-sided printing. Add additional input capacity to 2300 pages for higher volume printing needs.



Lexmark solutions

Reduce unnecessary printing and simplify work processes through solutions applications preloaded on your device. Choose additional Lexmark solutions to fit your unique workflow needs.



Direct USB

The front USB port allows for convenient walk-up preview, printing and scanning and is compatible with most printable image file formats.



Lexmark's Unison™ toner

Advanced toner science—powerful enough to deliver consistently outstanding image quality, with a shake-free print system.



Eco-friendly features

Easy-to-access features like eco-mode to reduce paper and toner consumption, the sleep button and hibernate mode make it easy to print responsibly and help you save energy.

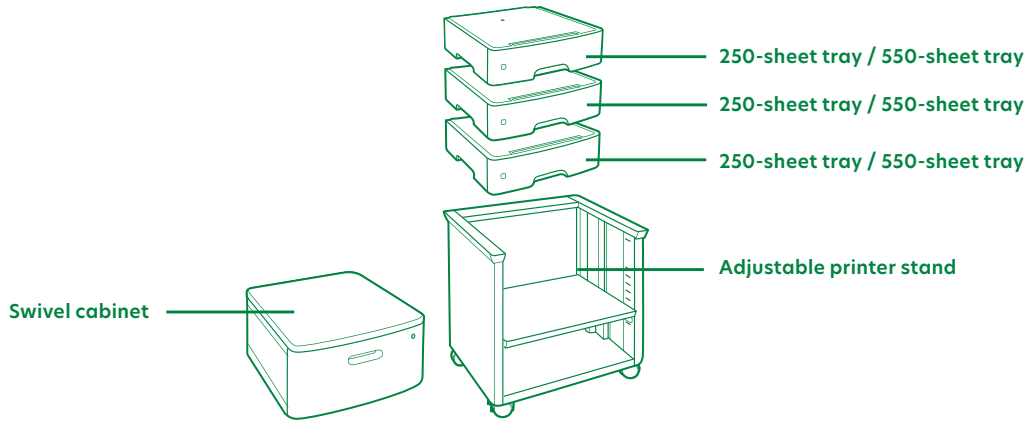
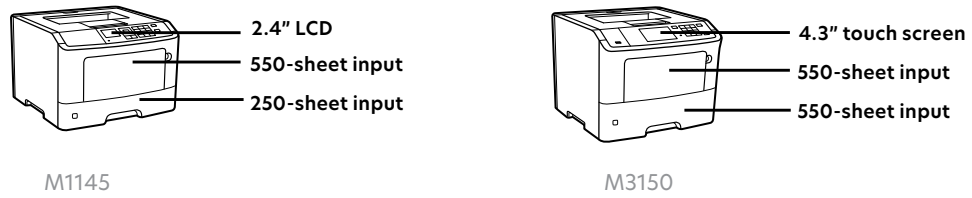

Standard
Optional

M1145 and M3150

Part # Models

35S0040 Lexmark M1145
35S0041 Lexmark M3150

Part # Laser toner/print cartridge

24B6035 Imaging Unit M1145, XM1145 Toner Cartridge
24B6040 Imaging Unit
24B6186 Toner Cartridge

Part # Paper handling

35S0567 550-sheet tray
35S0267 250-sheet tray

Part # Furniture

35S8502 Adjustable printer stand
3073173 Swivel cabinet

Part # Memory options

27X0210 160+ GB Hard Disk
57X9014 512MBx16 DDR3-DRAM
57X9016 1024MBx32 DDR3-DRAM
57X9012 2048MBx32 DDR3-DRAM
57X9011 1024MBx16 DDR3-DRAM
57X9101 256MB Flash Memory Card
57X9115 Japanese Font Card
57X9114 Korean Font Card
57X9112 Simplified Chinese Font Card
57X9110 Simplified Chinese Font Card

Part # Application solutions

35S2993 MS510dn, MS610dn card for IPDS
35S2992 MS510dn, MS610dn forms and barcode card
35S2994 MS510dn, MS610dn card for PRESCRIBE Emulation
34S4501 MS610de card for IPDS
34S4500 MS610de forms and barcode card
34S4502 MS610de card for PRESCRIBE Emulation

Part # Connectivity

1021294 USB (2 meter) cable
27X0128 Lexmark MarkNet 8352 802.11b/g/n Wireless
27X0901 Parallel 1284-B Interface Card
1021231 Parallel cable (10-foot)
27X0900 RS-232C Serial Interface Card

Part # Service parts

40X8281 MS510 Fuser Maintenance Kit, 110-120V
40X8434 MS610de Fuser Maintenance Kit, 110-120V

Monochrome laser product



Product specifications	Lexmark M1145	Lexmark M3150
Printing		
Display	2.4-inch (60 mm) Color LCD display	Lexmark e-Task 4.3-inch (10.9 cm) colour touch screen
Print Speed: Up to ²	Black: 45 ppm	Black: 50 ppm
Time to First Page: As fast as	Black: 6.5 seconds	
Print Resolution	Black: 600 x 600 dpi, 2400 Image Quality, 1200 x 1200 dpi, 1200 Image Quality	
Memory / Processor	Standard: 256 MB / Maximum: 1280 MB / Dual Core, 800 MHz	Standard: 512 MB / Maximum: 2560 MB / Dual Core, 800 MHz
Hard Disk	Not Available	Option available
Recommended Monthly Page Volume ⁶	1500 - 14000 pages	3000 - 16000 pages
Maximum Monthly Duty Cycle: Up to ²	120000 pages per month	175000 pages per month
Supplies		
Laser Cartridge Yields (up to) ¹	16,000-page Extra High Yield Cartridge	
Imaging Unit Estimated Yield: Up to ³	60000 pages, based on 3 average letter/A4-size pages per print job and ~ 5% coverage	
Cartridge(s) Shipping with Product ⁷	6,000-page Starter Return Program Toner Cartridge	
Paper Handling		
Included Paper Handling	Integrated Duplex, 150-Sheet Output Bin, 100-Sheet Multipurpose Feeder, 250-Sheet Input	250-Sheet Output Bin, Integrated Duplex, 100-Sheet Multipurpose Feeder, 550-Sheet Input
Optional Paper Handling	550-Sheet Lockable Tray, 550-Sheet Tray, 250-Sheet Tray	
Paper Input Capacity: Up to	Standard: 350 pages 20 lb or 75 gsm bond / Maximum: 2000 pages 20 lb or 75 gsm bond	Standard: 650 pages 20 lb or 75 gsm bond / Maximum: 2300 pages 20 lb or 75 gsm bond
Paper Output Capacity: Up to	Standard: 150 pages 20 lb or 75 gsm bond / Maximum: 150 pages 20 lb or 75 gsm bond	Standard: 250 pages 20 lb or 75 gsm bond / Maximum: 250 pages 20 lb or 75 gsm bond
Media Types Supported	Refer to the Card Stock & Label Guide., Transparencies, Plain Paper, Paper Labels, Envelopes, Card Stock	
Media Sizes Supported	A6, Oficio, Universal, Statement, Letter, Legal, JIS-B5, Folio, Executive, DL Envelope, A5, A4, 9 Envelope, 7 3/4 Envelope, 10 Envelope	
General Information⁴		
Standard Ports	Gigabit Ethernet (10/100/1000), USB 2.0 Specification Hi-Speed Certified (Type B)	Rear USB 2.0 Specification Hi-Speed Certified Port (Type A), Front USB 2.0 Specification Hi-Speed Certified port (Type A), Gigabit Ethernet (10/100/1000), USB 2.0 Specification Hi-Speed Certified (Type B), One Internal Card Slot
Optional Network Ports / Optional Local Ports	MarkNet N8352 802.11b/g/n Wireless	MarkNet N8352 802.11b/g/n Wireless / Internal 1284-B Bidirectional Parallel, Internal RS-232C serial
Noise Level: Operating	Print: 55 dBA	
Specified Operating Environment	Altitude: 0 - 2896 Meters (9,500 Feet), Humidity: 8 to 80% Relative Humidity, Temperature: 16 to 32°C (60 to 90°F)	
Size (in. - H x W x D) / Weight (lb.)	10.3 x 15.7 x 15.0 in. / 33.1 lb.	12.1 x 15.7 x 15.6 in. / 35.7 lb.

¹Average yield based on approximately 5% print coverage. ²Print and copy speeds measured in accordance with ISO/IEC 24734 and ISO/IEC 24735 respectively (ESAT). For more information see: www.lexmark.com/ISOspeeds. ³Actual Yield may vary based on other factors such as device speed, paper size and feed orientation, toner coverage, tray source, percentage of black-only printing and average print job complexity. ⁴Printers are sold subject to certain license/agreement conditions. See www.lexmark.com/printerlicense for details. ⁵"Maximum Monthly Duty Cycle" is defined as the maximum number of pages a device could deliver in a month using a multishift operation. This metric provides a comparison of robustness in relation to other Lexmark printers and MFPs. ⁶"Recommended Monthly Page Volume" is a range of pages that helps customers evaluate Lexmark's product offerings based on the average number of pages customers plan to print on the device each month. Lexmark recommends that the number of pages per month be within the stated range for optimum device performance, based on factors including: supplies replacement intervals, paper loading intervals, speed, and typical customer usage. ⁷Average standard page yield value declared in accordance with ISO/IEC 19752.

© 2015 Lexmark and the Lexmark logo are trademarks of Lexmark International, Inc., registered in the United States and/or other countries. All other trademarks are the property of their respective owners. ENERGY STAR® is a U.S. registered mark.

AirPrint and the AirPrint logo are trademarks of Apple Inc.

